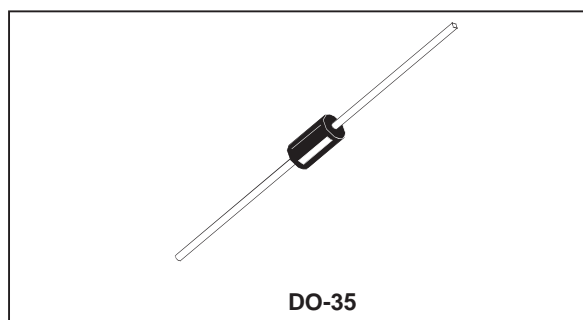


## SMALL SIGNAL SCHOTTKY DIODE

### DESCRIPTION

Metal to silicon junction diode featuring high break-down, low turn-on voltage and ultrafast switching. Primarily intended for high level UHF/VHF detection and pulse application with broad dynamic range. Matched batches are available on request



### ABSOLUTE RATINGS (limiting values)

Symbol	Parameter		Value	Unit
$V_{RRM}$	Repetitive Peak Reverse Voltage		70	V
$I_F$	Forward Continuous Current*	$T_a = 25^\circ\text{C}$	15	mA
$P_{tot}$	Power Dissipation*	$T_a = 25^\circ\text{C}$	430	mW
$T_{stg}$ $T_j$	Storage and Junction Temperature Range		- 65 to 200 - 65 to 200	$^\circ\text{C}$
$T_L$	Maximum Lead Temperature for Soldering during 10s at 4mm from Case		230	$^\circ\text{C}$

### THERMAL RESISTANCE

Symbol	Test Conditions	Value	Unit
$R_{th(j-a)}$	Junction-ambient*	400	$^\circ\text{C/W}$

### ELECTRICAL CHARACTERISTICS

#### STATIC CHARACTERISTICS

Symbol	Test Conditions		Min.	Typ.	Max.	Unit
$V_{BR}$	$T_{amb} = 25^\circ\text{C}$	$I_R = 10\mu\text{A}$	70			V
$V_F^{**}$	$T_{amb} = 25^\circ\text{C}$	$I_F = 1\text{mA}$			0.41	V
	$T_{amb} = 25^\circ\text{C}$	$I_F = 15\text{mA}$			1	
$I_R^{**}$	$T_{amb} = 25^\circ\text{C}$	$V_R = 50\text{V}$			0.2	$\mu\text{A}$

#### DYNAMIC CHARACTERISTICS

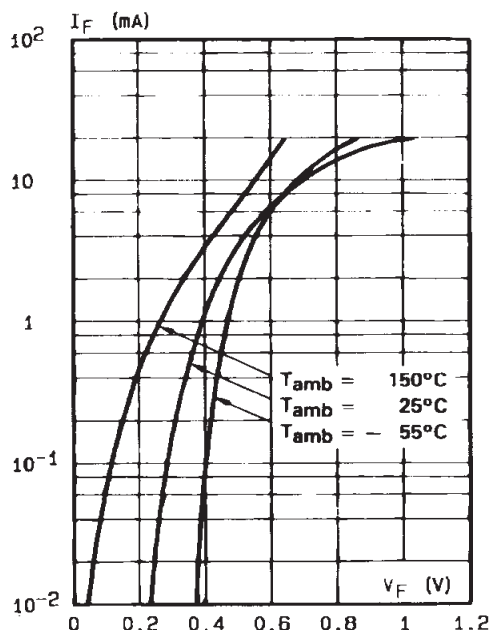
Symbol	Test Conditions			Min.	Typ.	Max.	Unit
C	$T_{amb} = 25^\circ\text{C}$	$V_R = 0\text{V}$	$f = 1\text{MHz}$			2	pF
$\tau$	$T_{amb} = 25^\circ\text{C}$	$I_F = 5\text{mA}$	Krakauer Method			100	ps

\* On infinite heatsink with 4mm lead length

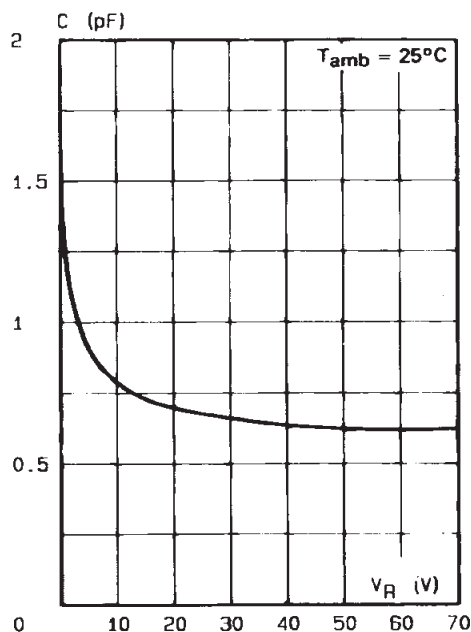
\*\* Pulse test:  $t_p \leq 300\mu\text{s}$   $\delta < 2\%$ .

Matched batches available on request. Test conditions (forward voltage and/or capacitance) according to customer specification.

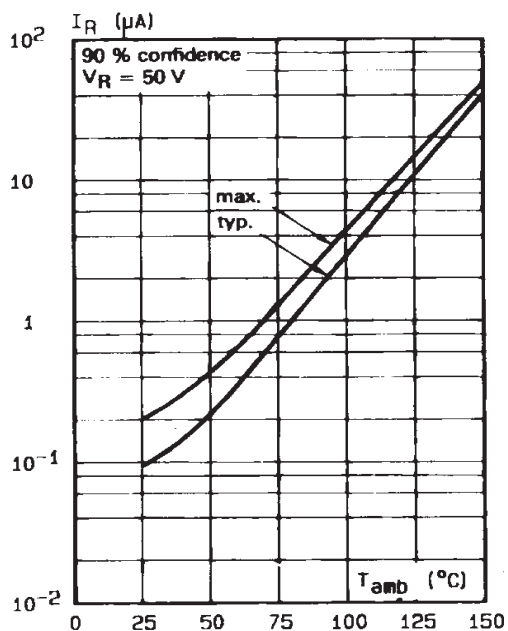
**Fig. 1:** Forward current versus forward voltage at low level (typical values).



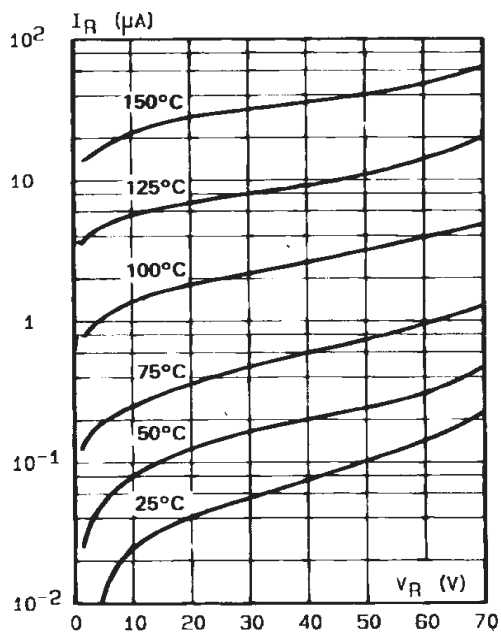
**Fig. 2:** Capacitance C versus reverse applied voltage  $V_R$  (typical values).



**Fig. 3:** Reverse current versus ambient temperature.

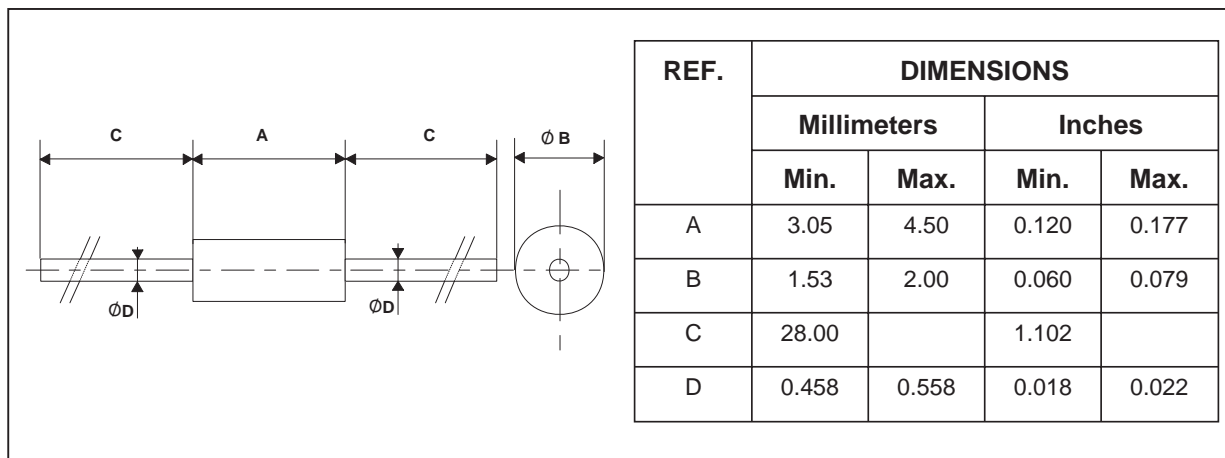


**Fig. 4:** Reverse current versus continuous reverse voltage (typical values).



## PACKAGE MECHANICAL DATA

DO-35



Cooling method : by convection and conduction

Marking: clear, ring at cathode end.

Weight: 0.15g

Information furnished is believed to be accurate and reliable. However, STMicroelectronics assumes no responsibility for the consequences of use of such information nor for any infringement of patents or other rights of third parties which may result from its use. No license is granted by implication or otherwise under any patent or patent rights of STMicroelectronics. Specifications mentioned in this publication are subject to change without notice. This publication supersedes and replaces all information previously supplied.

STMicroelectronics products are not authorized for use as critical components in life support devices or systems without express written approval of STMicroelectronics.

The ST logo is a registered trademark of STMicroelectronics

© 2001 STMicroelectronics - Printed in Italy - All rights reserved.

STMicroelectronics GROUP OF COMPANIES

Australia - Brazil - China - Finland - France - Germany - Hong Kong - India - Italy - Japan - Malaysia

Malta - Morocco - Singapore - Spain - Sweden - Switzerland - United Kingdom - U.S.A.

<http://www.st.com>

## X-ON Electronics

Largest Supplier of Electrical and Electronic Components

*Click to view similar products for [Schottky Diodes & Rectifiers](#) category:*

*Click to view products by [STMicroelectronics](#) manufacturer:*

Other Similar products are found below :

[CUS06\(Te85L,Q,M\)](#) [MA4E2508M-1112](#) [D1FH3-5063](#) [MBR0530L-TP](#) [MBR10100CT-BP](#) [MBR30H100MFST1G](#) [MMBD301M3T5G](#)  
[PMAD1103-LF](#) [PMAD1108-LF](#) [RB160M-50TR](#) [RB520S-30](#) [RB551V-30](#) [D83C](#) [DD350N18K](#) [DZ435N40K](#) [DZ600N16K](#)  
[BAS16E6433HTMA1](#) [BAS 3010S-02LRH E6327](#) [BAT 15-099R E6327](#) [BAT 54-02LRH E6327](#) [NRVBAF360T3G](#) [NRVTS10100MFST1G](#)  
[NRVTS12100EMFST1G](#) [NSR05F40QNXT5G](#) [NSVR05F40NXT5G](#) [JANS1N6640](#) [SB07-03C-TB-H](#) [SB1003M3-TL-W](#) [SBAT54CWT1G](#)  
[SK32A-LTP](#) [SK33A-TP](#) [SK34A-TP](#) [SK34B-TP](#) [SMD1200PL-TP](#) [ACDBN160-HF](#) [SS3003CH-TL-E](#) [STPS3045CPIRG](#) [STPS30S45CW](#)  
[PDS3100Q-7](#) [GA01SHT18](#) [CRS10I30A\(Te85L,QM\)](#) [CRS10I30B\(Te85L,QM\)](#) [MBR1240MFST1G](#) [MBR20100CT-BP](#) [MBRB30H30CT-1G](#)  
[BAS28E6433HTMA1](#) [BAS 70-02L E6327](#) [BYS11-90-E3TR3](#) [JANTX1N5712-1](#) [VS-STPS40L45CW-N3](#)