

## 1Hz-50MHz Crystal Oscillator Frequency Counter Meter DIY Kit

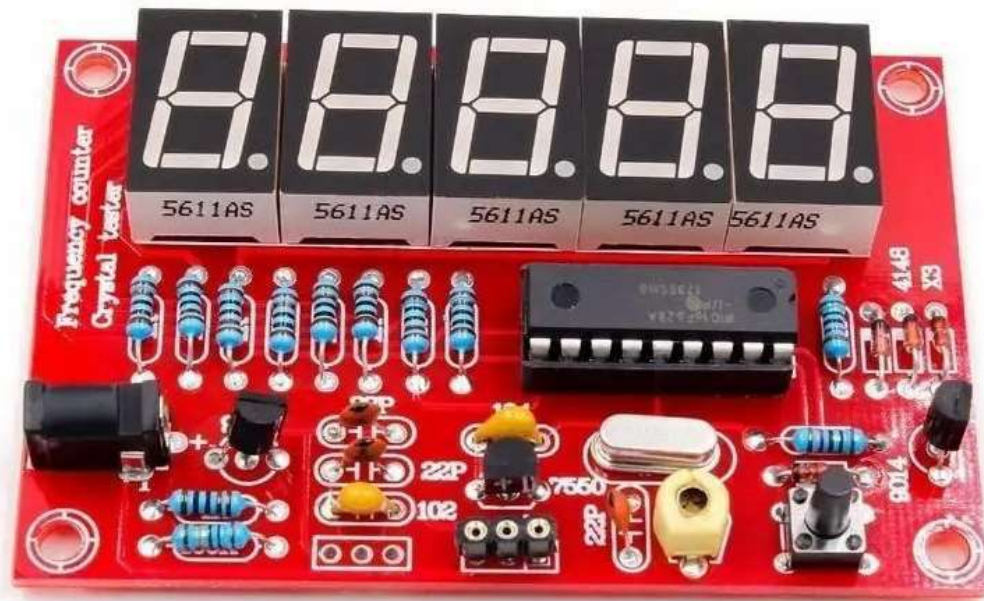

- Frequency range 1 Hz ... 50 MHz
- Five digits resolution (display for example x.xxxx kHz, x.xxxx MHz, or xx.xxx MHz)
- Measuring signal amplitude can be up to 30 v
- Crystals measure 4-40 MHz
- Measurement accuracy:  $\pm 0.1\text{Hz}$  for frequencies below 10 MHz, :  $\pm 0.3\text{Hz}$  for frequencies between 10 MHz and 50 MHz
- Input impedance: Approx.  $1\text{ M}\Omega$
- Sensitivity: 10 mVrms
- Automatic range switching with different gate times
- Optional addition or subtraction of a frequency offset (programmable)
- Very low component count: a PIC 16F628, 5 7-segment LED displays, a 20MHz crystal and a few resistors
- Optional (configurable) power-saving mode turns off the display off if the frequency didn't change significantly within 15seconds
- USB 5V or DC5-12V power supply can be used

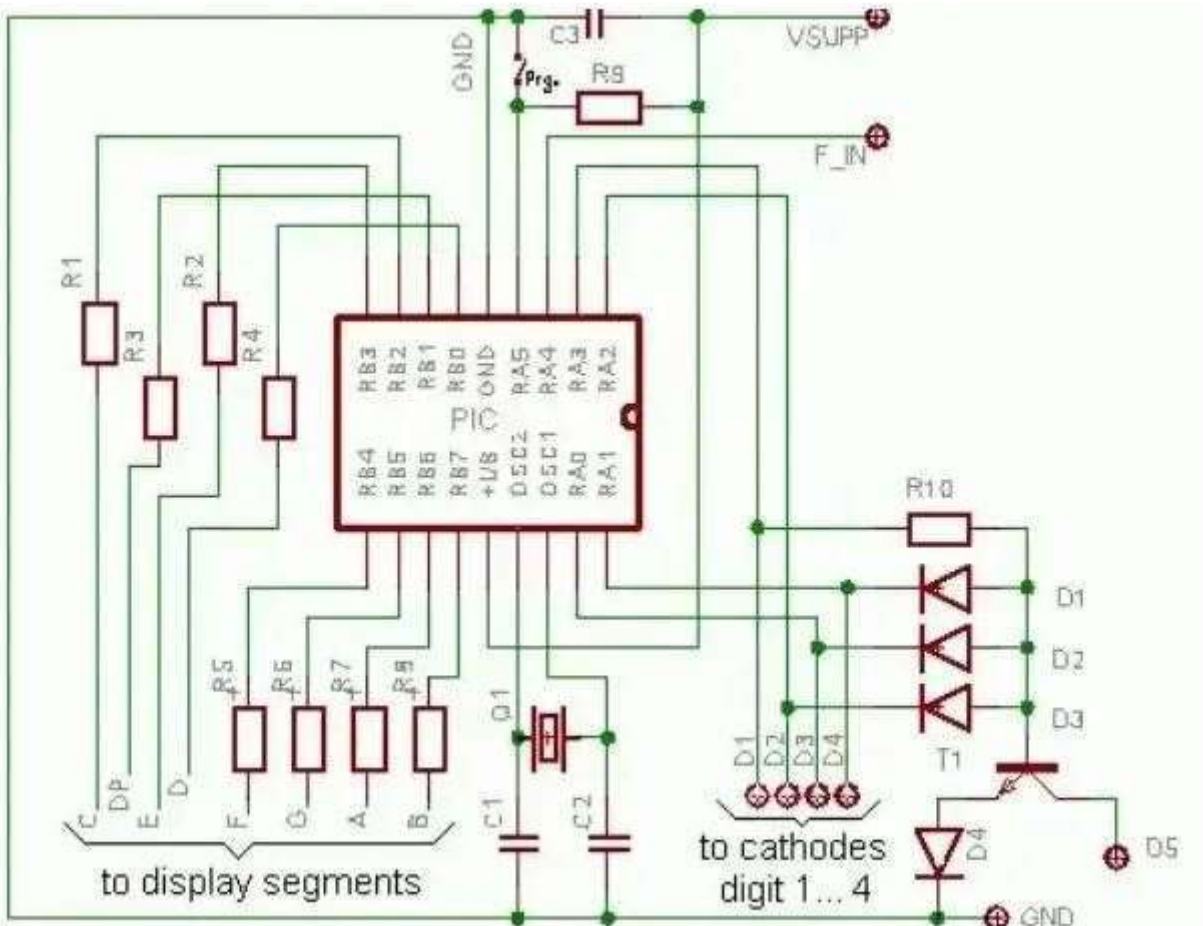

The crystal oscillator of 32.768kHz cannot be measured. The crystal oscillator of 4-20MHz and 48MHz can also be measured due to limited conditions. However, since this kind of crystal oscillator uses a 3 times harmonic wave, the crystal oscillator of 48MHz will display the fundamental wave frequency of 16MHz, as shown in the figure below:

It is also possible to directly input frequency signals between IN and G (ground) for measurement, taking care that the measured signal amplitude is not higher than 5V to avoid damaging IC. The following figure shows the input of 1Hz and 10kHz:

All the directly inserted components can be welded correctly according to PCB silk screen printing. After the welding, input signal with standard signal source and adjust the yellow adjustable capacitance to make the display value equal to the signal frequency. The signal generator can be used for adjustment. If there is no standard signal, the crystal vibration can be used for direct calibration with better accuracy.