

NEMA 17 42mm 17HS8401 Hybrid Stepper Motor

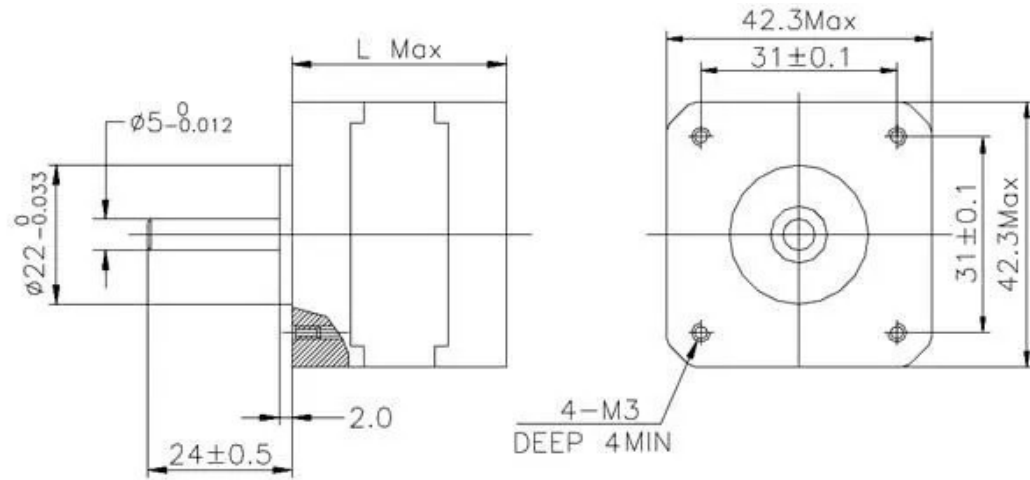

| Model | Length |
|----------|--------|
| 17HS2XXX | 28 mm |
| 17HS3XXX | 34 mm |
| 17HS4XXX | 40 mm |
| 17HS8XXX | 48 mm |
| 17HS6XXX | 60 mm |

| Model | Step Angle (deg) | Motor Length (mm) | Rated Current (A) | Phase resistance (ohm) | Phase inductance (mH) | Holding Torque (N-cm min) | Detent Torque (N-cm max) | Rotor Inertia (g-cm ²) | Number of wires | Motor weight (g) |
|----------|------------------|-------------------|-------------------|------------------------|-----------------------|---------------------------|--------------------------|------------------------------------|-----------------|------------------|
| 17HS8401 | 1.8 | 48 | 1.7 | 1.8 | 3.2 | 52 | 2.6 | 68 | 4 | 350 |

